

## Silicon Microphone Product Specification

### IR -2921 -AB -3868

Analog bottom mount MEMS Microphone

#### IR Sensors and Systems Technology

The IR Sensors and Systems (IR) Product of a MEMS capacitive silicon microphones is patented and designed in a package sized 2.95 mm x 2.15 mm.

SNR of 68 dB and sensitivity of -38dBV allows for a variety of applications where size, sensitivity and noise matters.

#### Description

The IR -2921 -AB -3868 Product series of MEMS capacitive silicon microphones are patented, advanced design microphones, developed and manufactured to cater to various customer applications and future requirements.

In this design, capacitive sensing technology is taken to the next level in which a single platform technology is able to cater to a wide range of SNR from low -68dB to highest -78dB and more to meet the next wave of microphone requirements.

Unique patented designs and processes offer world class state of the art microphone for high volume and high -performance applications.

The patented design allows high SNR and smaller die size which allows smaller package ( 2.95 mm x 2.15 mm ) meeting the demand for future ever smaller footprints.

#### Features

- Omni directional
- Low Noise
- Small SMD package
- Bottom & top mount
- Low frequency roll off by design
- JEDEC compatible
- RoHS compatible
- Tape & Reel packing

#### Typical Applications

- Mobile Phones
- Laptop / PC / Tablet
- Automotive
- Door Bell
- Audio devices
- Earphone
- Remote Sensing
- Home Automation

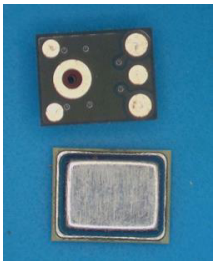



Ordering Information

Product ID	Package	Marking	Order Code
IR2921AB3868	MP-B-2921-68	IR01	IR01022001

# Silicon Microphone Product Specification

## PRODUCT KEY PERFORMANCE SPECIFICATIONS

Technical Specification: All data taken at 25±2°C, Relative Humidity 45±5% unless otherwise specified.

### General Ratings Specifications

SPECIFICATION	MINIMUM	TYPICAL	MAXIMUM	UNITS
Operating Temperature	-40	-	+85	°C
Storage Temperature	-40	-	+100	°C
MSL (moisture sensitivity Level)	Class 1			

### Product Key Acoustic Performance Specification

PARAMETER	SYMBOL	TEST CONDITION	VALUES			UNITS
			MIN	TYP	MAX	
Directivity			Omni-directional			
Sensitivity	S	94 dB SPL @ 1kHz	-40	-38	-36	dB V/Pa
Signal to Noise Ratio	SNR	94 dB SPL @ 1kHz, A-weighted		68		dB
Total Harmonic Distortion	THD	94 dB SPL @ 1kHz			0.1	%
Acoustic Over Pressure	AOP	10% THD @ 1kHz		>130		dB SPL
Low Frequency Roll-off	LFCO			20		Hz
High Frequency Flatness		+3dB relative to @ 1KHz		10		kHz

# Silicon Microphone Product Specification

## Electrical Key Characteristics and Performance

PARAMETER	SYMBOL	TEST CONDITION	VALUES			UNITS
			MIN	TYP	MAX	
Input / Supply Voltage	V <sub>DD</sub>		1.5	2.5	3.3	V
Input current	I <sub>DD</sub>	V <sub>DD</sub> =1.5V-3.3V	90	115	130	μA
Output impedance	Z <sub>OUT</sub>	94 dB SPL @ 1kHz, Single-ended output	-	-	200	Ohm
Power Supply Rejection	PSR	100mVpp Square wave @217Hz, A-weighted		-103		dBFS
Power Supply Rejection Ratio	PSRR	200mVpp sine wave at 1kHz, V <sub>DD</sub> =1.8V		70		dB
DC output voltage	V <sub>OUT_DC</sub>	V <sub>DD</sub> =1.5V-3.3V, Single ended output		0.85		V
Start-up time	t <sub>Start</sub>	Single-ended output		15		mS
Equivalent input noise	EIN	Noise measured with A-weighted filter		3		μV

## TYPICAL FREQUENCY RESPONSE CURVE

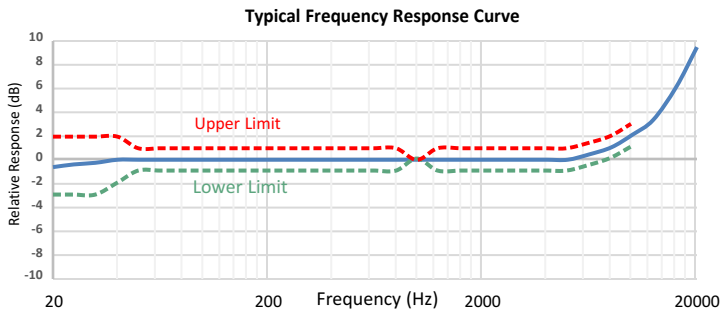

# Silicon Microphone Product Specification

## ELECTRICAL PIN LAYOUT

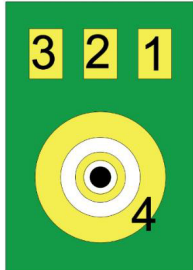

Bottom View

Pin #	Pin Name	Type	Description
1	Output	Signal	Output Signal
2	GND	Ground	Ground
3	VDD	Power	Power Supply
4	GND	Ground	Ground

## Terminology

1. **POWER:** The Supply Voltage Positive Terminal (Pad name “VDD” in Electrical layout drawing) which is connected to the Microphone Sensing Element.
2. **OUTPUT:** The Output Terminal, where the electrical signal equivalent to the acoustic pressure is available, i.e the Microphone output. (Pad name “OUTPUT” in Electrical layout drawing)
3. **COMMON:** The Terminal where the supply negative (Pad name “GND” in Electrical layout drawing) is connected to microphone package.
4. **SENSITIVITY:** Sensitivity is the open circuit output voltage amplitude for a given sound pressure at the microphone diaphragm. This is frequency dependent so typically quoted at 1KHz. Units are defined in dB logarithmic scale.
5. **FREQUENCY RESPONSE:** It is the plot of Sensitivity in dB vs frequency [Hz], it depends on transducer mechanism directional response, and reflection from room boundaries – usually quote free-field response.
6. **DIRECTIVITY:** It is the response pattern that expresses the geometric shape of the region of sensitivity surrounding the microphone, omni directional, uni directional, bi-directional.

## FUNCTIONAL BLOCK DIAGRAM

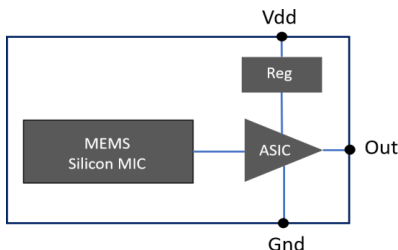

## ELECTRICAL BLOCK DIAGRAM

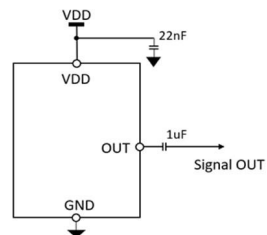

# Silicon Microphone Product Specification

## PACKAGE DIMENSION

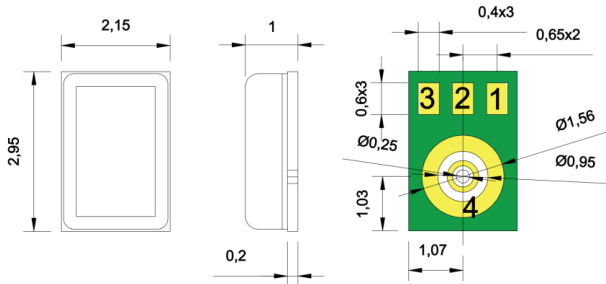

Item	Dimension	Tolerance(+/-)	Units
Length(L)	2.95	0.10	mm
Width(W)	2.15	0.10	mm
Height(H)	1.0	0.10	mm
Acoustic Port(AP)	$\varnothing 0.25$	0.05	mm

Pin #	Pin Name	Type	Description
1	Output	Signal	Output Signal
2	GND	Ground	Ground
3	VDD	Power	Power Supply
4	GND	Ground	Ground

### Notes:

All dimensions are in millimeter (mm).

Tolerance  $\pm 0.15$  mm unless otherwise specified.



## Silicon Microphone Product Specification

### Packaging Information

#### Tape & Reel Specification

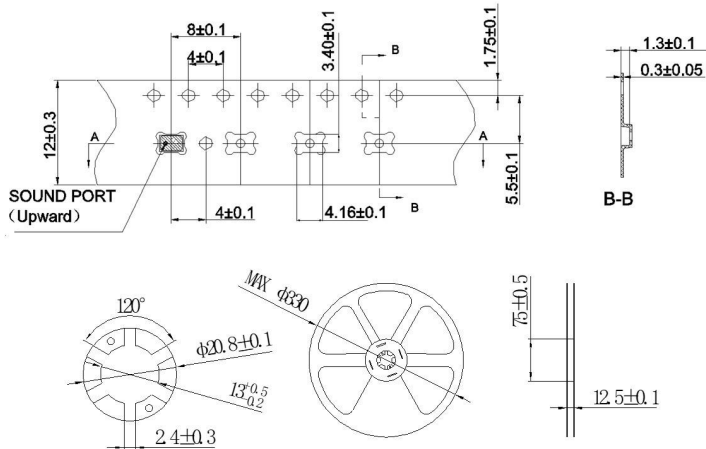

Notes  
All dimensions are in millimeter (mm).

### Packaging Information

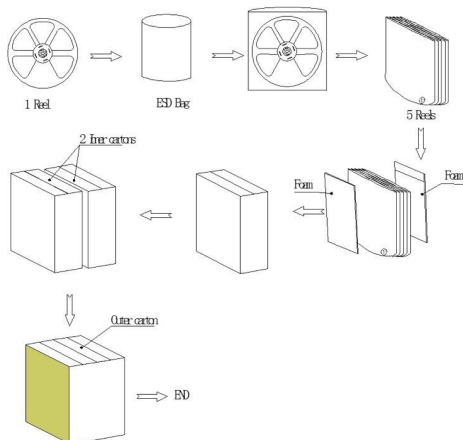

Packaging quantity:
1 Reel=5000pcs
1 Inner Carton =5Reels=25000pcs
1 Outer Carton=2 Inner Cartons=50000pcs

# Silicon Microphone Product Specification

## PROCESSING INFORMATION

### Recommended Reflow Process Condition:

Recommend reflow profile, solder reflow  $\leq 260^{\circ}\text{C}$  (for 30s Max of peak temperature).

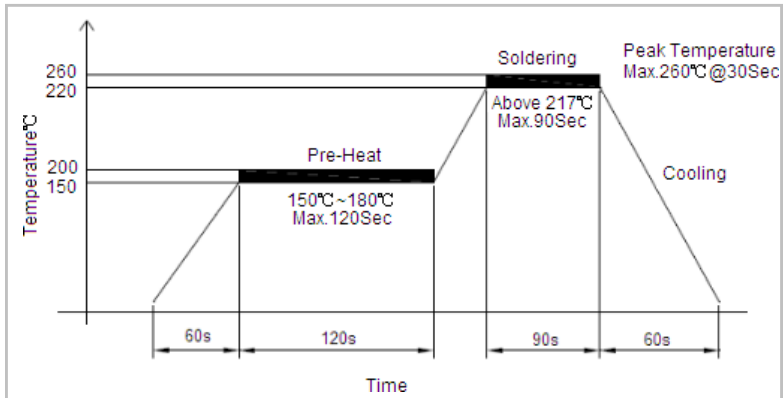

### Important Notes

In order to minimize device damage:

- Do not boards wash or clean after the reflow process.
- Do not apply the airflow which pressure over 0.3MPa blow into the port hole within a distance of less than 5 cm.
- Do not expose to ultrasonic processing or cleaning.
- Do not pull a vacuum over port hole of the microphone

### Pickup Tool Pick Location & PCB Solder Pad Layout:

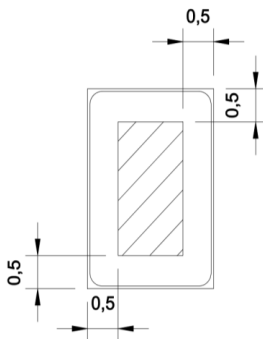

Recommended Pickup Location

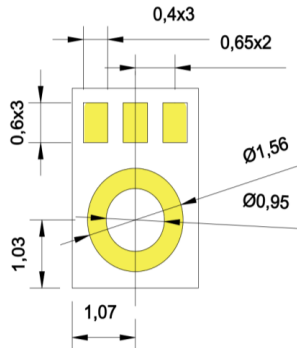

Recommended Solder Pad Layout



# Silicon Microphone Product Specification

## TEST SETUP

### Sensitivity Test in Anechoic Room

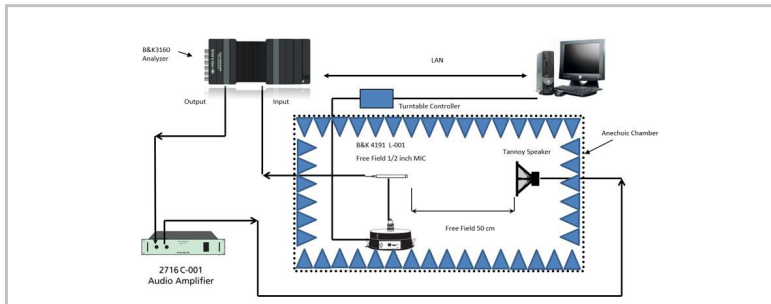

### Measurement Circuit

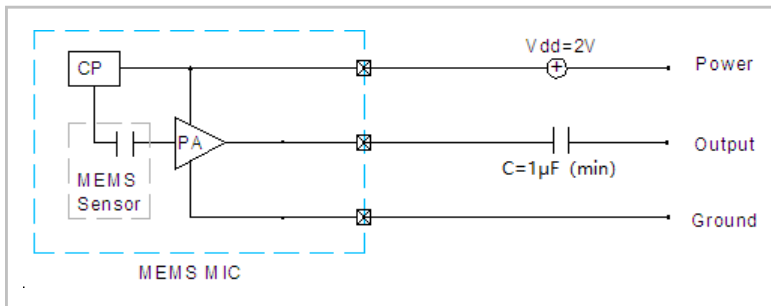

## Silicon Microphone Product Specification

### RELIABILITY TEST

The samples should be placed in the room with  $23\pm 2^{\circ}\text{C}$ ,  $55\pm 10\%$ R.H. for 2 hours at least before final measurement, unless otherwise specified.

Item	Detail	Standard
Simulated Reflow (Without Solder)	Samples for qualification testing require 3 Times $260\pm 5^{\circ}\text{C}$ reflow solder profiles. 2 hours of setting time is required between each reflow profile test.	$\pm 3$ dB
Static Humidity	Precondition at $+25^{\circ}\text{C}$ for 1 hour. Then expose to $+85^{\circ}\text{C}$ with 85% relative humidity for 1000 hours.	$\pm 3$ dB
Temperature Shock	Each cycle shall consist of 30 minutes at $-40^{\circ}\text{C}$ , 30 minutes at $+125^{\circ}\text{C}$ with 5 minutes transition time. Test duration is for 30 cycles, starting from cold to hot temperature.	$\pm 3$ dB
ESD Sensitivity	Perform ESD sensitivity threshold measurements for each contact according to MIL -STD-883G, Method 3015.7 for Human Body Model. Identify the ESD threshold levels indicating passage of 8000V Human Body Model.	$\pm 3$ dB
Random Vibrations	Vibrate randomly along three perpendicular directions for 30 minutes in each direction, 4cycles from 20Hz~2000Hz with a peak acceleration 20g.	$\pm 3$ dB
Mechanical Shock	Subject samples to half sine shock pulses ( $3000\text{g}\pm 15\%$ for 0.3ms) in each direction, totally 18 shocks.	$\pm 3$ dB
Operation Life	Subject samples to $+125^{\circ}\text{C}$ for 168 hours under full maximum rated voltage.	$\pm 3$ dB
Drop Test	The test was repeated in six directions for three times, Dropped from 1.5m height on to a steel surface, total 18 times and inspected for mechanical damage. Note: Sensitivity should vary within $\pm 3$ dB from initial sensitivity after test conditions are performed.	$\pm 3$ dB

### Delivery Standard:

- Product delivered with 100% tested
- Product tested 100% for Sensitivity @ 1KHz
- Product samples tested for Frequency curve and SNR



## Silicon Microphone Product Specification

### PRODUCT NAMING CONVENTION

Company name IR Sensors &Systems	Packaging size Length (mm) Width (mm)	Output A = Analog D = Digital	Mount T=Top Mount B= Bottom mount	Sensitivity -dB (V/Pa)	Noise dB	Status
IR	2921	A	B	38	68	Active

### DOCUMENT HISTORY

Document Version	Date of Release	Changes
1.0	Sept. 15 <sup>th</sup> , 2022	Initial Version

### INTERNATIONAL CONTACT INFORMATION

#### SINGAPORE

Anu Austin

Address: 200, Cantonment Road,  
#05-03/04 Southpoint  
Singapore-089763

Phone number: **+65 96235457**

Email address:

[anu.austin@irsensorssystems.com](mailto:anu.austin@irsensorssystems.com)

#### INDIA

Memstech

Address: 83 A2, New no: 136 Bharathi Colony, 3rd Street,  
Peelamedu, Coimbatore - 641 004, Tamilnadu, India

Branch office:

5/63 OMR Egattur Chennai - 600130, Tamilnadu, India

Phone number: **+91 84898 13526**

Email address:

[guru@memstech.com](mailto:guru@memstech.com)

#### EUROPE

Dieter Naegle

Address: Heimesgasse19d,  
Ingelheim am Rhein-55218

Phone number: +4915253923397

Email address:

[dieter.naegle@irsensorssystems.com](mailto:dieter.naegle@irsensorssystems.com)

#### NORTH AMERICA

K. Sooriakumar

Address: 75 Boniface Drive  
Rochester, NY 14620

Phone number: +1 585 7362223

Email address:

[k.soori@irsensorssystems.com](mailto:k.soori@irsensorssystems.com)